

SEAMLESS
MOVEMENT

HOME GLIDE

ACCESS



The HomeGlide aluminium rail has a slim design giving a modern and clean look.

02

The HomeGlide stairlift delivers a solution for all straight staircase requirements and budgets. Designed for effortless simplicity with superior comfort and value. The HomeGlide is fitted onto your staircase and not your wall. This allows the lift to be installed quickly, efficiently and with minimal disruption to your home.

//

I am so happy with my HomeGlide stairlift. It's very comfortable, and the ride is super smooth. The service from the technicians from my local dealer was excellent, and I would highly recommend it to anyone looking for a new stairlift!"



03

1

Comfort Designed For You

The generous and luxurious padding ensures a firm and comfortable seat with plenty of support. The warm grey colour of the upholstery is a modern neutral tone which will blend seamlessly in every household. The upholstery is also fire retardant, liquid repellent and easy to clean. The HomeGlide is operated with an easy-to-use joystick and requires minimal effort to use the lift.



2



2

Compact & Discreet

The HomeGlide has a timeless design and is effortlessly simple, sturdy and satisfies your mobility requirements. The soft rounded shapes, are easy on the eye, allowing the HomeGlide to sit discreetly within the home. Remote control handsets allow the HomeGlide to park at either the top or bottom of the staircase, wherever is the most convenient for you. When not in use, the HomeGlide can be folded away to only 385mm (15") on any landing, out of the way of other staircase users.

3

Safety & Control

Your safety is of paramount importance to us. The HomeGlide stairlift is certified to machine directive 2006/42/EC, EN 81-40:2020 and UKCA standards. During travel, the retractable, easily accessible seatbelt will keep you secure on the stairlift. If the lift encounters an obstacle, it will safely come to a stop due to special safety edges on the drive unit and footrest. In addition, the stairlift is battery-operated, which means you can still use it during a power cut.

The HomeGlide offers an optional integrated call device feature (programmable up to three telephone numbers) to ensure you can stay connected with friends and family when using the lift.

It is designed to glide effortlessly along an aluminium track, providing an attractive, elegant and discreet addition to your home. Engineered with modern manufacturing techniques and technology, the HomeGlide stairlift range can be fitted to almost all straight staircases as narrow as 740mm (29") and has a maximum weight capacity of 160kg (25st).



When you choose the HomeGlide stairlift, you ensure an ideal solution for your staircase. With a smooth aluminium track, this stairlift can be installed on almost any straight staircase.

06 It's all about you

Joystick



With a comfortable soft-touch grip, the integrated joystick is user-friendly and requires minimal effort to take you up and down your staircase with ease.

Seat belt



A retractable seatbelt keeps you secure while using your HomeGlide stairlift. The integrated sensor ensures the seatbelt is fastened securely before travel, and the stainless steel buckle is designed to be operated with just one hand.

Folding Rail



If you have an obstruction at the foot of the staircase, you can choose to have an automatically powered hinge installed. Once you have used your stairlift, it will return to the top of the stairs, and the lower section of the rail will fold away, leaving the bottom of your staircase clear.

Call Device



Our optional call device ensures you stay connected with friends and family, with up to three different telephone numbers stored and contactable directly from your stairlift.

The HomeGlide includes intuitive remote control units at the top and bottom of the stairs so you can call your lift and send it to a parking point when not in use. With a modern handheld design and a neutral colour palette, they sit discreetly on the wall without intrusion.

08

Added Comfort with the HomeGlide Extra Package

By choosing the HomeGlide Extra package, you receive all of the features and benefits of the HomeGlide standard with further features to ensure the most comfortable ride. The HomeGlide Extra proves to be the ultimate marriage of design and functionality for any straight staircase.



09

1

Linked footrest

With the HomeGlide Extra package, your HomeGlide comes with a powered linked footrest. This feature makes it almost effortless when unfolding the chair as the footrest is connected to the seat - eliminating the need to bend down and have any unnecessary strain on your body.

2

Ergonomic seat

Designed by ergonomic experts, all HomeGlide models feature an ergonomic moulded seat designed to positively influence your posture while offering maximum comfort during travel. In addition, with the HomeGlide Extra package, you can choose from four different seat heights, providing a more tailored fit, ensuring the most comfortable seating position possible.

3

Powered swivel seat

The HomeGlide Extra package automatically upgrades you to the powered swivel seat. The powered swivel feature automatically turns the chair at the top landing as you maintain pressure on the joystick. This enables a safe exit from the chair as the lift automatically rotates towards the staircase landing.

4

Keylock

To prevent unauthorised or accidental use of your HomeGlide stairlift, the HomeGlide Extra and Outdoor package comes fitted with a dedicated keylock. This enables you to isolate the lift to specific people and is particularly useful with children or grandchildren visiting or if your lift is used in a public setting.

An ergonomic single moulded seat is designed to provide maximum security and support.



With the HomeGlide Outdoor package, you can enjoy outdoor access whatever the weather.

HOMEGLIDE Outdoor access aLL yEar round

12



The HomeGlide Outdoor package has successfully passed a range of industry-accepted corrosion, rain protection and climate testing to ensure reliability and performance. In addition, it has specially treated components to provide a stairlift that can be used any time of the year.



A weatherproof coating on all exposed parts of the lift protects against rain, dust and direct sunlight. In addition, a water-resistant cover is provided to give additional protection to the lift when not in use.

13

PaC k aG E ovErviEw



Features & Options	Standard	Extra	Outdoor
Max user weight 160kg (25st) at 45°	•	•	•
Max user weight 136kg (21st) at 53°	•	•	•
Easy-to-use joystick	•	•	•
Armrest detection	•	•	•
Emergency stop button	•	•	•
One-hand operation seatbelt with detection	•	•	•
Vinyl seat upholstery	•	•	
Powered swivel		•	
Powered linked footrest		•	
Seat height adjustment		•	
Keylock		•	•
Outdoor protection, including outdoor cover			•
Call device	Optional	Optional	Optional
Folding rail	Optional	Optional	

tECHNICAL sPEcIFICATION

Driving Speed

Drive Type

Motor Wattage	0.12 m/s (23.6ft/min)
Weight Capacity	Rack and pinion
	280 W
	160kg (25st) at max 45° 136kg (21st) at max 53° 145kg (22st) with hinge
Batteries	2 x 12V, 7Ah (indoor) 2 x 12V, 9Ah (outdoor)
Operation	Joystick
Staircase Incline	28° up to 53° (up to 45° for use in 160kg range)
Certification	Machine Directive 2006/42/EC EN 81-40:2020 UKCA RP00-ST
Model Code	Yes
Automatic Stop	Yes
Footrest	Yes
Retractable Seatbelt	



I had been looking for a straight stairlift to add to my product portfolio, and I eventually found HomeGlide online. I like that it's a very modern-looking stairlift, but it's also a great product to keep in stock for quick turnaround times."

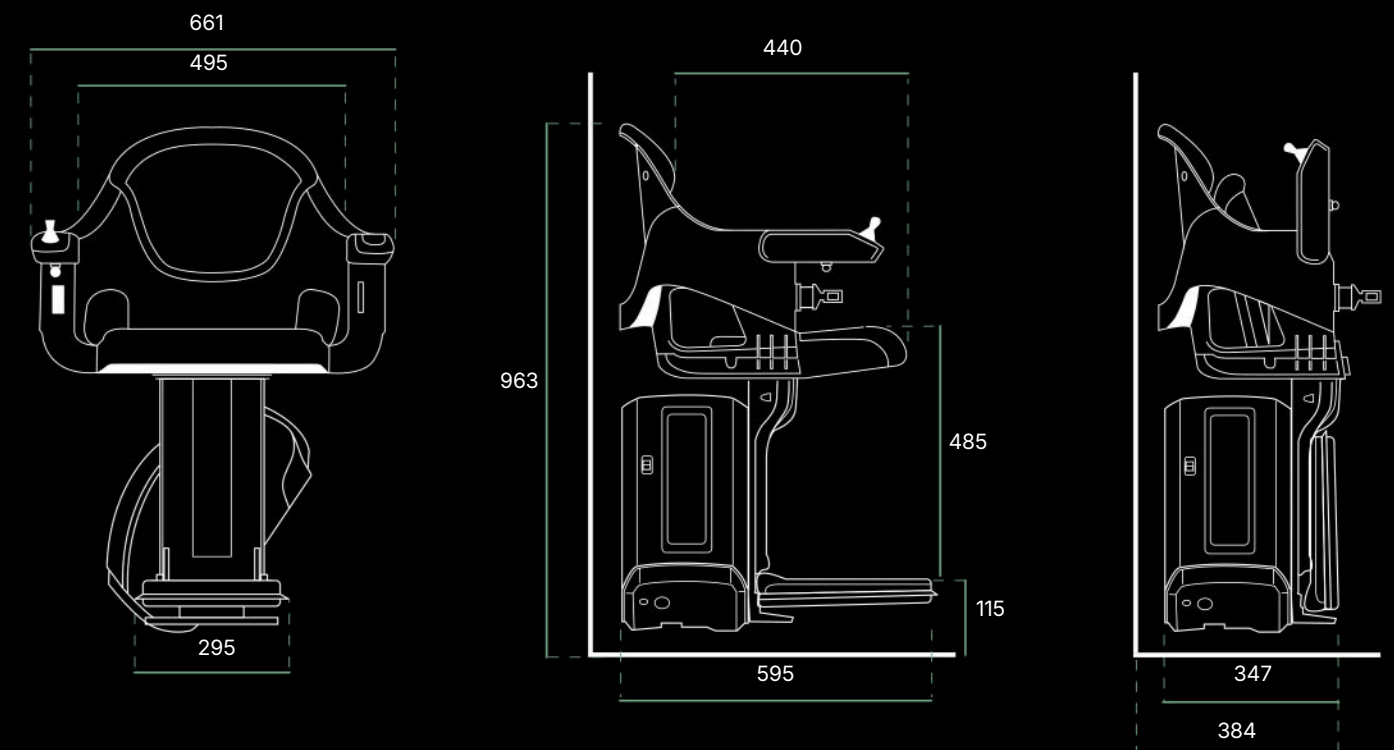

The HomeGlide proves to be the ultimate marriage of design and functionality for any straight staircase.

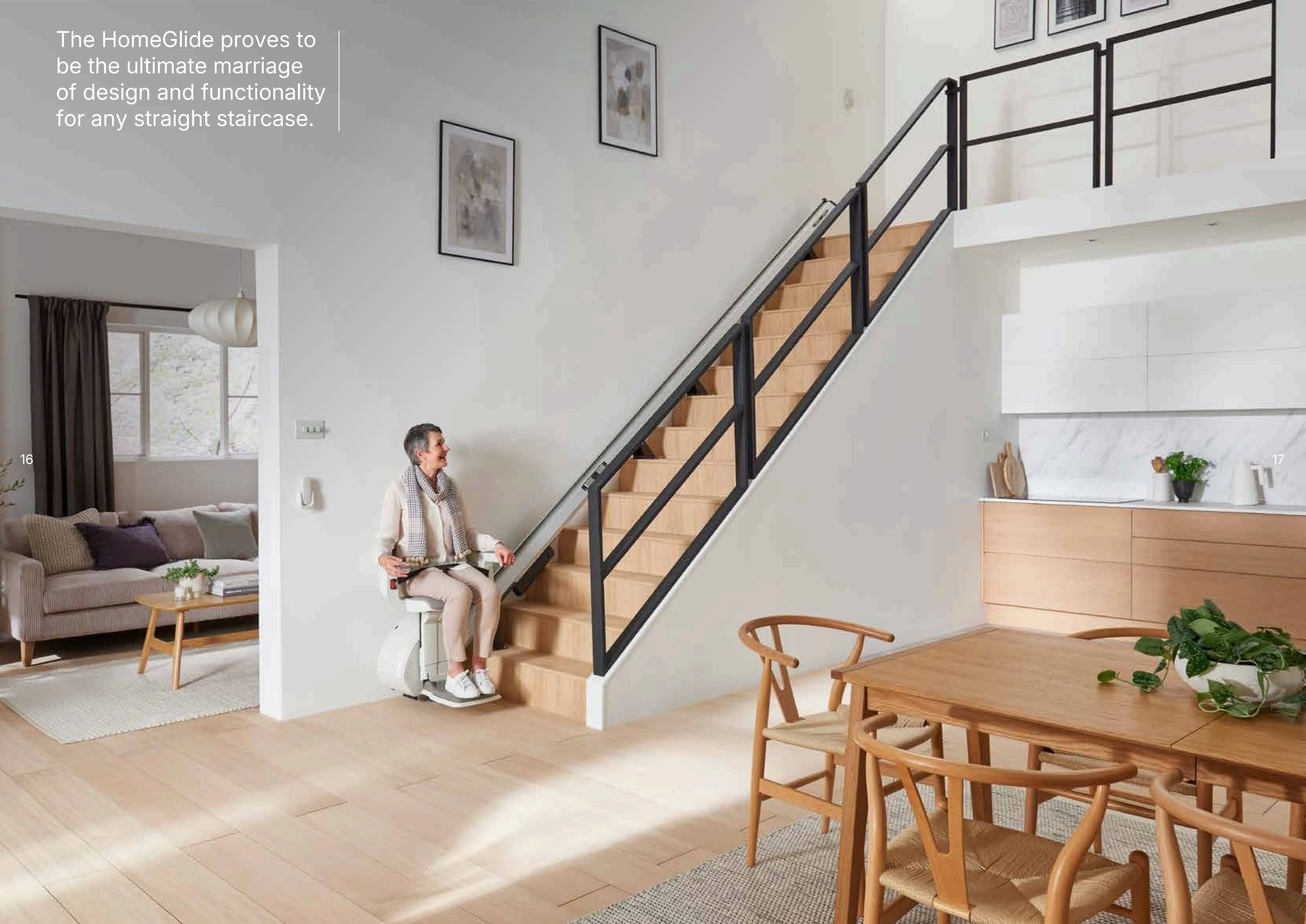

Our products are designed for easy installation and maintenance, with everything taken care of by your Access BDD approved partner.

Since 1976 we've been simplifying complex choices to help people move around their homes.



18

19

about access

Access BDD is a division of TK Access Solutions Ltd. We enable people around the world the ability to move comfortably around buildings by providing stairlifts, platform lifts and home lifts, which we distribute via a network of carefully chosen business partners. When you choose an Access BDD lift, you're choosing a high-quality product, supported by expert service and advice.

Our partners are all specialists in mobility or elevator products, and they receive extensive technical and commercial training on our products. Your Access BDD partner will guide you through the product options to help you choose a lift that meets your own needs and suits your surroundings. You'll also receive expert advice to ensure that your new lift conforms to relevant accessibility and safety regulations.

Access BDD is one of the world's leading suppliers of stairlifts, platform lifts and home lift solutions.



Scan to watch our HomeGlide customer journey video.

Your local Access BDD partner is:

CandorCare
...a lift when you need it most

**APPROVED
DEALER**

 **0330 100 4564**

