

## Handicare 1100

Our signature straight stairlift

The ultra-slim Handicare 1100 sits close to the wall, maximising space for other stair users, while its foldable seat, footrest, and armrests offer even more convenience.

# Handicare 1100 | Our signature straight stairlift

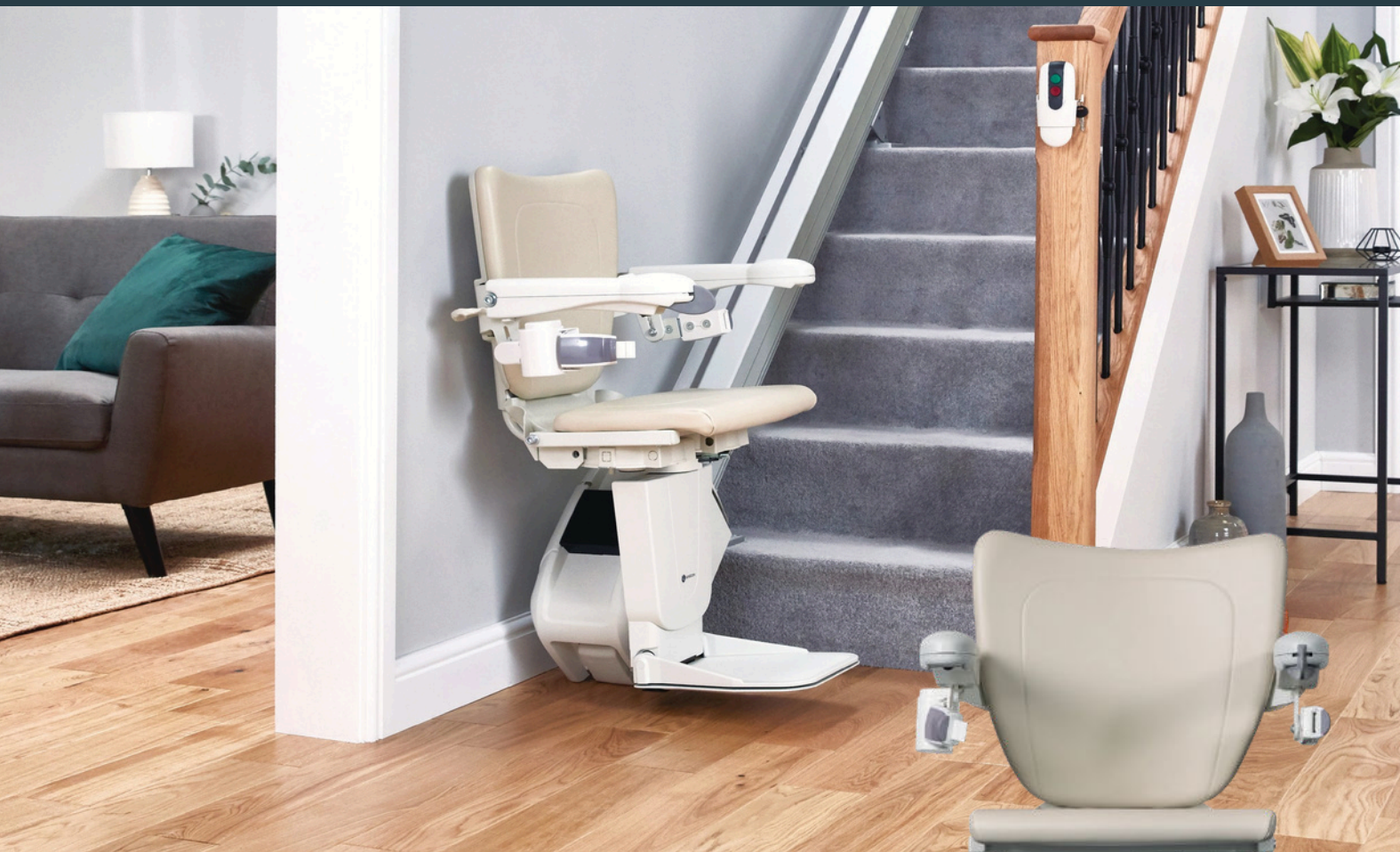

The Handicare 1100 stairlift features unique friction drive technology rather than a tooth rack and pinion wheel to operate. This means no grease, no gears and an ultra quiet lift.

#### The style seat

A polished design (in vanilla) that's built for comfort. Adjustable seat height comes as standard.

Vanilla



#### Easy hinge

Easy! Simply fold up the rail to clear the doorway. The lightweight folding hinge rail is effortlessly folded out of the way to clear the hallway, while the stairlift is in a parked position.



#### Zero intrusion

This unique solution is designed for homes with a door at the top of the stairs. It eliminates the rail overrun, allowing you to install a Handicare 1100 stairlift without making modifications to your home.



#### Slide track

Unique to Handicare, our slide track is ideal for hallways where access is required through doorways either at the top and/or bottom of the stairs. It automatically slides the track clear of any obstacles while the stairlift moves up or down the track.

Scan the QR-code to see the Slide Track in action



## Features



#### Energy efficient

Low running costs and batteries that remain operational if there's a power cut. The 1100 charges whenever it's parked to keep the batteries fully powered



#### Easy to maintain

No tooth rack on the rail, so no grease, which makes it very easy to keep clean.



#### Safety

Interlocking seatbelt - the stairlift will not move until the seatbelt is fastened. Other optional features include an emergency stop button, safety sensors and One Touch Alert.



#### Optional extras

Easily upgrade with additional options to suit your needs today and tomorrow. Powered swivel seat, powered folding footrest and velcro seatbelts available.



#### Compact

Folds to leave more room on the stairs when not in use. One of the slimmest rails on the market.



#### Easy to use

Scan the QR-code to watch our video showing how to use the 1100.



## One Touch Alert

With the simple press of a button, you can dial your emergency contacts directly from your stairlift through the new Savaria One Touch Alert. A discreet yet invaluable feature that utilises two-way communication, the system connects you with assistance swiftly and reliably, if required.



# Handicare 1100 | Our signature straight stairlift

## Dimensions & specifications

<b>A</b>	Minimum swivel radius	645mm
<b>B</b>	Wall to inner seat back	60mm
<b>C</b>	Seat depth	390mm
<b>D</b>	Minimum folded width to footplate	320mm
<b>E</b>	Minimum open width to edge footplate	530mm
<b>F</b>	Armrest width – external	575mm
<b>G</b>	Armrest width – internal	450mm
<b>H</b>	Seat back height	400mm
<b>I</b>	Footplate to seat height	430-520mm
<b>J</b>	Minimum footplate height	70mm
<b>K</b>	Minimum track intrusion into staircase	160mm
	Maximum weight limit	25-45°-140kg 46-50°-130kg
	Speed	0.15m/sec
	Power supply	2x12V batteries
	Staircase angle	25-50°

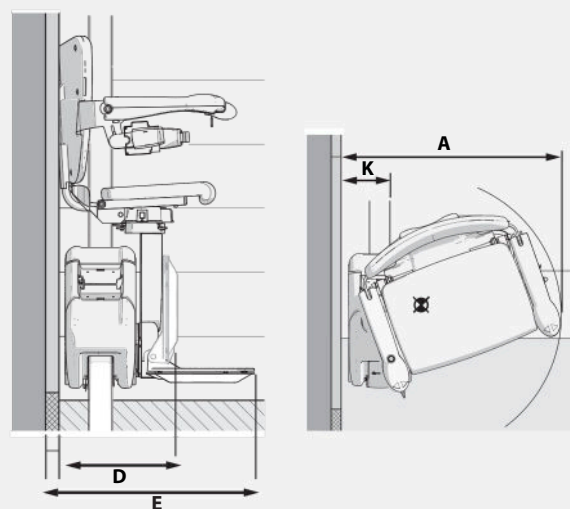
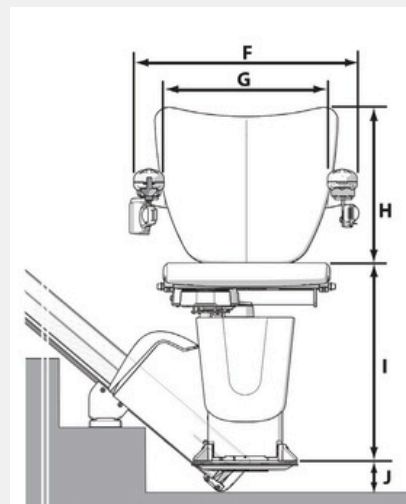

Dimensions may vary depending on the specific characteristics of the staircase in the home. All information and images are provided for illustrative purposes only and are subject to change. While provided in good faith, they do not constitute a guarantee. Handicare reserves the right to alter designs and specifications without prior notice.

Authorised Dealer:



With a rich history of product innovation and service excellence in the lift industry dating back more than 100 years, Handicare designs and makes straight and curved stairlifts for indoor and outdoor installations, which are sold in over 50 countries worldwide.



Handicare Stairlifts UK, 82 First Avenue,  
Pensnett Estate, Kingswinford,  
West Midlands, DY6 7FJ  
[www.handicare-stairlifts.co.uk](http://www.handicare-stairlifts.co.uk)

Handicare is part of Savaria Corporation.

With a shared vision of empowering mobility for life, our over 2400 employees reach global markets with products that provide barrier-free access in the home and public buildings.

