



Handicare 1000

Our strongest straight stairlift

The Handicare 1000 provides a sleek, discreet solution and can be equipped with a number of automatic options.

Handicare 1000 | Our strongest straight stairlift

The Handicare 1000 blends into your home seamlessly with its hidden tooth rack. Its slim aluminium rail features two parking points for battery charging at the top and bottom of the stairs.



Color options

Seat colors



Great outdoors

The 1000 is suitable for outdoor use too. Improved UV-protected upholstery provides longevity outdoors, with a water-resistant cover (IP44 rated) for additional protection. A key switch prevents unauthorised use.



Perch seat

For those with limited knee or hip movement, or even for really narrow stairways, the perch seat is the perfect choice. The raised seat and the reduced seat depth allow you to use the stairlift in a standing position, whilst still being secured by a seatbelt.



Choice of hinges

Easy! Simply fold up the rail to clear the doorway. The lightweight folding hinge rail is effortlessly folded out of the way, while the stairlift is in a parked position. A powered folding hinge can also be added to prevent obstruction at the bottom and an adjustable seat height comes as standard.



Features



Energy efficient

Low running costs and batteries that remain operational if there's a power cut.



Capacity

Heavy duty version can carry up to 200kg.



Safety

Interlocking seatbelt – the stairlift will not move until the seatbelt is fastened. Other optional features include an emergency stop button, safety sensors and One Touch Alert.



Optional extras

Easily upgrade with additional options to suit your needs today and tomorrow. Powered swivel seat, powered folding footrest and various seatbelts available.



Easy to use

Scan the QR-code to watch our video showing how to use the 1000.



One Touch Alert

With the simple press of a button, you can dial your emergency contacts directly from your stairlift through the new Savaria One Touch Alert. A discreet yet invaluable feature that utilises two-way communication, the system connects you with assistance swiftly and reliably, if required.



Handicare 1000 | Our strongest straight stairlift

Dimensions & specifications

Smart seat diagram shown for example purposes only.

	Smart	Perch
A Wall to innerseatback	75mm*	75mm
B Seat depth With extendedseat	360mm 425mm	247mm -
C Minimum foldedwidthtofootplate	385mm*	385mm
D Minimum openwidthtoedgefootplate	650mm*	650mm
E Armrest width-external With armrest spacers With extendedarmrestspacers	550mm 590mm 635mm	550mm - -
F Armrest width-internal With armrest spacers With extendedarmrestspacers	465mm 520mm 565mm	465mm - -
G Seat backheight	455mm	455mm
H Footplate to seat height	465-540mm	675-875mm**
I Minimum footplate height	70mm	70mm
Seat basetofoldedarmrest	-	597mm
Seat basetofoldedbarrierarm	-	745mm
Minimum track intrusion into staircase	115mm	115mm
Standard weight limit	137kg	137kg
Maximum weight limit	160kg	160kg
Extra heavy duty version (XXL)	200kg***	-
Heavy duty version (XL)	160kg***	-
Speed	0.07m/sec	0.07m/sec
Power supply	2x12V batteries	2x12V batteries
Staircase angle	21-56°	21-56°

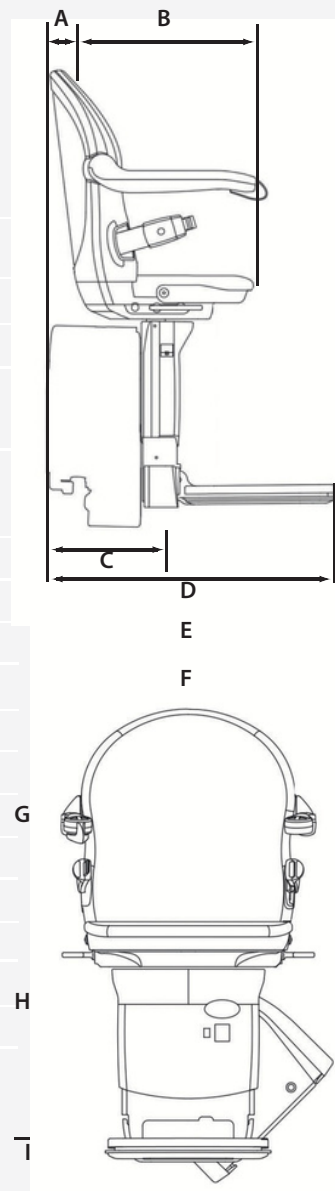

*+45mm for extra heavy duty (XXL) two-way swivel with extended armrest spacers.

Not available for extra heavy duty (XXL).

Not available with hinged rail.

Dimensions may vary depending on the specific characteristics of the staircase in the home. All information and images are provided for illustrative purposes only and are subject to change. While provided in good faith, they do not constitute a guarantee. Handicare reserves the right to alter designs and specifications without prior notice.

Authorised Dealer:



Handicare Stairlifts UK, 82 First Avenue,
Pensnett Estate, Kingswinford,
West Midlands, DY6 7FJ
www.handicare-stairlifts.co.uk

Handicare is part of Savaria Corporation.

With a shared vision of empowering mobility for life, our over 2400 employees reach global markets with products that provide barrier-free access in the home and public buildings.

